

---

## United We Stand, Divided We Fall: A Model of Virtual Collaborative Community to Support National Education Agenda

Mat Rahimi Yusof<sup>1</sup>, Hapini Awang<sup>2</sup>, Ramlan Mustapha<sup>3</sup>, Mohd Faiz Mohd Yaakob<sup>4</sup>, Mohd Fairuz Jafar<sup>5</sup>, Mohd Zaini Zakaria<sup>6</sup> & Mohd Yusri Ibrahim<sup>7</sup>

<sup>1,4,5</sup>School of Education, Universiti Utara Malaysia

<sup>2</sup>School of Computing, Universiti Utara Malaysia

<sup>3</sup>ACIS, Universiti Teknologi MARA Pahang, Raub Campus

<sup>6</sup>Faculty of Quranic and Sunnah, Universiti Sains Islam Malaysia

<sup>7</sup>Department of Language and Communication, Universiti Malaysia Terengganu

---

### Abstract

The national education transformation agenda has put a clear aspiration and direction on the involvement of parents and communities in education. This has been apparently stated in the Malaysia Education Blueprint 2013-2025 through the ninth pillar which stated the strategies to encourage mutual partnerships with parents, communities, and private sectors. Apart from the hard work of all parties, leadership styles and communication are also among the key elements that need to be addressed to realize this aspiration. To ensure its sustainability, the nature of this collaboration needs to be flexible by considering certain limitations caused by unstable situations, including the COVID-19 pandemic. Based on Joyce Epstein's model, this quantitative study aims to confirm the dimensions and constructs in the model of virtual collaborative community in education. An instrument consisting of six dimensions of collaborative community which contains 30 questionnaire items were used. The dimensions are, i) parenting, ii) communication, iii) volunteering, iv) learning at home, v) decision making (leadership), and vi) smart partnership. The survey data was collected from 246 respondents using a quantitative approach through questionnaires, which were later analyzed using the AMOS version 22 software. The finding shows that all six proposed functions for community involvement variables are significant. Finally, a model of virtual collaborative community to support national education agenda was successfully developed (CFI = 0.931; PCFI = 0.802; PNFI = 0.752; RMSEA = 0.064).

**Keywords:** School Leadership, Communication, Collaborative Community, Virtual Community, National Education Agenda

---

\*\* Corresponding author: Hapini Awang, School of Computing, Universiti Utara Malaysia, e-mail: hapini.awang@uum.edu.my

## **Introduction**

School is an educational agent of society. It is also a social institution that connects all social units in the society such as parents, communities, alumni, institutions of higher learning, private sectors and local authorities (Sander, 2001). Hence, a collaboration between schools and these other entities is crucial for enhancing relationships and effectiveness of education (Aziah Ismail & Abdullah, 2013; Mattar et al., 2013; Sheldon, 2015). School collaboration with the community in education took place since the days before independence and continues to be emphasized in every education agenda beginning with the Razak Statement 1956 until it was enacted by the Education Act, 1966 (Mohammed Sani et al., 2013; Siti Aliah, Muhamad Suhaimai, & Jamaluddin, 2016). Entering the era of the Industrial Revolution 4.0, this engagement was given a new life through the educational transformation in the National Education Blueprint (MEB 2013-2025). In the ninth shift pillar, it is stated that “Partner with parents, community, and private sector at a big scale”, which proved that this is a vital strategy to drive the national education agenda (Ministry of Education, 2013).

Local researchers of this century are emphasizing the involvement of parents in children's learning, the leadership of school leaders, and the effective communication as the key elements in determining the success of school engagement with the community (Paezah & Faridah, 2017; Simon, 2017). This trend is parallel to those studies conducted over the last decades, indicating that positive changes in school are attributed to the collaborations between school and community which are directly involved in the education process (Coutts, Sheridan, Kwon, & Semke, 2012; Sanders & Epstein, 2005). Consequently, this has led to the improvement of academic achievement, diversity of learning experiences, attendance, emotion and personality. Furthermore, the changes have created safe situations in schools, enhanced parenting skills and promoted community involvement (Gross et al., 2015). Even though some studies have shown that the result of school collaboration with communities and parents is benefitting both sides, the reality of community engagement is still weak and not yet fully achieved (Mohammed Sani & Jamalul Lail, 2012; Siti Aliah et al., 2016). In light of this, it is found that the community has less role to play in the activities or programs organized by the Parents Teacher Association (PTA).

Some parents dedicated their child's education wholly to schools but not understanding the concepts and advantages of schooling in collaboration with the community (Mohammed Sani & Jamalul Lail, 2012; Siti Aliah et al., 2016). Besides, some schools are placing too much priority on academics and neglecting the importance of having a good relationship with the community. This has caused the depletion of the community's role in helping students' academic excellence and the school's effectiveness (Epstein & Sanders, 2006; Mohammed Sani, Ibrahim Saedah & Norlidah, 2014). These issues are relevant with the findings of the prior studies that pointed to some of the issues in realizing the involvement of schools with communities such as the form of effective engagement and how to establish engagement programs (Epstein, 2016; Sanders, 2015). Recognizing the importance of school and collaborative community in the effectiveness of the school and student achievements, this study is very important to be done on an ongoing basis. However, with the occurrence of uncertain situations like the COVID-19 pandemic, the nature of collaborations needs to be adjusted. One of the mediums to do so is by manipulating the existing Information and Communication Technology (ICT) tools. Hence, the researchers felt that it was time to develop a model of virtual collaborative community in education under the country's educational environment.

## **Research Objectives**

This study aims at validating the proposed dimensions and constructs in the hypothesis model of collaborative community in Terengganu coastal secondary schools. Some aspects will be emphasized, namely the construct validation in the dimensions of collaborative community, the validity of the items for each collaborative community construct as well as the compatibility of the acquired data with the proposed measurement model.

## **Research Conceptual Framework**

Based on the literature review on related issues and available models or theories, the research conceptual framework was developed as shown in Figure 1. In this conceptual framework, collaborative community is a variable represented by six constructs namely parenting, volunteering, communicating, learning at home, decision making and smart partnership.

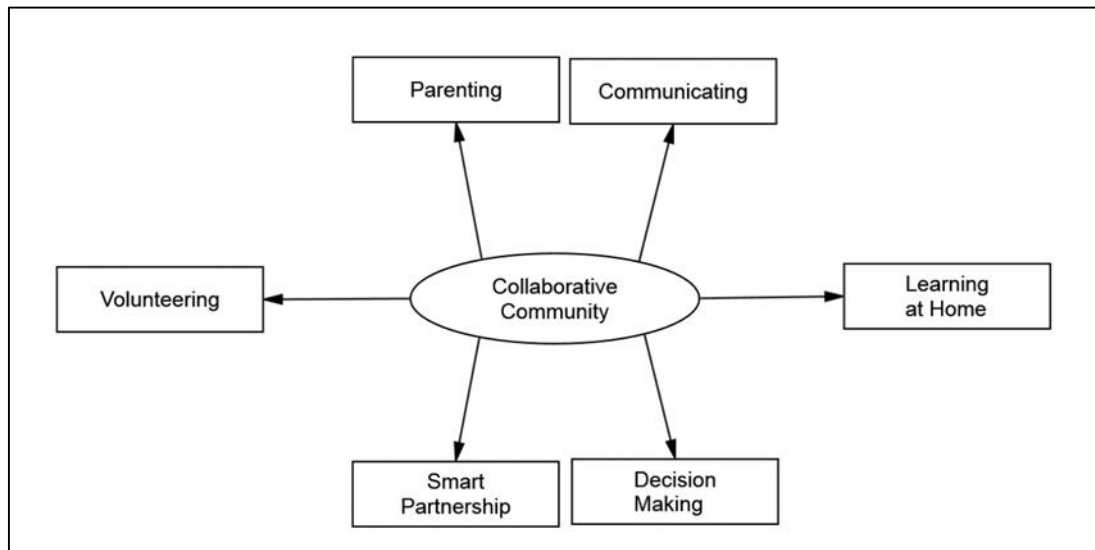

Figure 1. Research Conceptual Framework

## Methodology

This quantitative study uses a cross-sectional design which examines the population by collecting data from a controlled sample (Air, Gay, & Mills, 2011; Lodico, T., Dean, Spaulding, & Voegtle, 2010). The sample of this study consists of 246 respondents chosen based on the stratified random sampling technique and Krejcie and Morgan's sample size determination formula (1970). The respondents are 80 or 32.5% male and 166 or 67.5% are female. Most of them are PTA committees or communities (113 or 45.2%), followed by teachers who are also committee members of PTA (77 or 31.3%) and parents or guardians (56 or 22.7%).

The data was collected using a modified questionnaire from the Parents Involvement Practices questionnaire (Epstein, 1986). The data was analyzed using Structural Equation Model (SEM) with the assistance of the AMOS 22 program. To validate the proposed factors, a Confirmatory Factor Analysis (CFA) is carried out. The proposed factors are accepted if the outer loading value is bigger than 0.708 (Hair, 2012). Nevertheless, if the outer loading value is similar or bigger than 0.4, they are accepted only when the Average Variance Extracted (AVE) value reaches the threshold, which is bigger than 0.5 (Hair, 2012). If the composite reliability value is bigger than 0.708, they are accepted (Hair et al, 2012). Furthermore, the accepted AVE value in convergent validity should be bigger than 0.5 (Hair et al, 2012; Zainuddin, 2014). When the Composite Reliability (CR) value is plus or minus 1.96 and the p significant value is lower than 0.5, it is assumed that the proposed factors have contributed significantly.

Next, the tested model is verified by using fit indexes such as  $\chi^2$  (CMIN), CFI, RMSEA, PCFI, and PNFI. The hypothesis model is considered equivalent with the research data when the  $\chi^2$  value is not significant, which is above 0.05 (Chua, 2009; Yusri, 2012; Meyers, Gamst & Guarino, 2013). The RMSEA value is exceptional if it is smaller than 0.08. Still, it is acceptable if it is less than 0.1 (Byrne, 2013; Yusri, 2012). This hypothesis model reflects as equivalent when the Goodness of Fit Index (GFI) value is higher than 0.90 (Chua, 2009; Meyers, Gamst & Guarino, 2013; Yusri, 2012). PNFI and PCFI fit index values are accepted if they are above 0.50 (Meyers, Gamst & Guarino, 2013). According to Hair et al (2010), and Joreskog and Sorbom (1984), in goodness for fit index measurement on a model, if three fit indexes are achieved, then the model is considered fit.

## Findings

To determine the validity of dimensions and functions that are proposed in the community's collaborative variable, the CFA is done. First, the regression weight value is observed, as shown in Table 1.

Table 1  
*Regression Weight for Collaborative Community*

			Estimate	S.E.	C.R.	P
LS	<---	KK	0.499	0.107	4.641	***
IB	<---	KK	0.861	0.131	6.565	***
SR	<---	KK	0.867	0.106	8.168	***
BR	<---	KK	1.000			
CL	<---	KK	0.262	0.075	3.491	***

Based on Table 1, the finding shows that all items obtain a critical ratio value greater than  $\pm 1.96$  and a significant value of  $<0.01$ . These results indicate that measured constructs which can be represented by the functions proposed are acceptable and significantly contributing. The second-order factor analysis shows that all the behaviors or functions proposed in the model of the virtual collaborative community are contributing to the regression weights and the proposed indicator items can be verified. The finding also shows that most of factor loading values for item indicators are above 0.5, except for items IB1, CM3, BR3, BR4, BR5, and LS1. These items were later dropped because the value of the loading factors and the AVE were less than the predetermined value. The following Table 2 shows the summary of the CFA results for the model of virtual collaborative community in education.

Table 2  
*Summary of the Confirmatory Factor Analysis Results*

Constructs	FL	AVE	CR	$\sqrt{\text{AVE}}$
Parenting	0.447-0.796	0.53	0.768	0.728
Communicating	0.405-0.712	0.589	0.81	0.900
Volunteering	0.640-0.809	0.519	0.842	0.720
Learning at home	0.243-0.858	0.719	0.837	0.848
Decision making (leadership)	0.462-0.802	0.554	0.829	0.744
Smart partnership (collaborating with community)	0.430-0.929	0.592	0.873	0.934

Furthermore, Table 3 displays the indicator items that are rejected representing parenting, learning at home, communicating and smart partnership.

Table 3  
*Rejected Behaviours in the Model of Virtual Collaborative Community in Education*

Constructs	Item	Behaviors	FL
Parenting	IB1	The school provide a parenting development workshop	0.447
Communicating	CM3	Create virtual communications channels like WhatsApp or telegram with communities	0.405
	BR3	Parents monitor the homework modules provided during school holidays	0.376
Learning at home	BR4	Help parents set student academic achievement	0.243
	BR5	The school provides homework logs for parents to review	0.324
Smart partnership	LS1	Community participation in the PTA and school safety committees	0.462

Next, Table 4 displays the summary of behaviors that are accepted in the Model of Virtual Collaborative Community in Education.

Table 4

*The Summary of Behaviors in the Model of Virtual Collaborative Community in Education*

Variable	Constructs	Accepted behavior	Rejected behavior
Collaborative Community	Smart partnership	5	0
	Learning at home	2	3
	Volunteering	5	0
	Communicating	4	1
	Decision making	4	1
	Parenting	4	1
	Total	26	6

Moreover, Table 5 exhibits all fit indexes to validate the proposed model and match it with the collected data. The finding shows that all tested fit indexes reach the desired level. Thus, the model of virtual collaborative community in education is validated.

Table 5

*Fit Indexes*

Fit Indexes	Suggested fit indexes value	Hypothesis model
$\chi^2$	-	398.505
Sig $\chi^2$	>0.05	.000
DF		199
Ratio (CMIN ( $\chi^2$ )/DF)	< 5.0	2.003
RMSEA (Root Mean Square Error of Approximation)	<0.08	0.064
CFI (Comparative Fit Index)	>0.90	.931
PCFI (Parsimony Comparative of Fit Index)	>0.50	.802
PNFI (Parsimony Normed Fit Index)	>0.50	.752

Finally, the model which has been developed consists of six functions and 26 behaviors is illustrated in Figure 2.

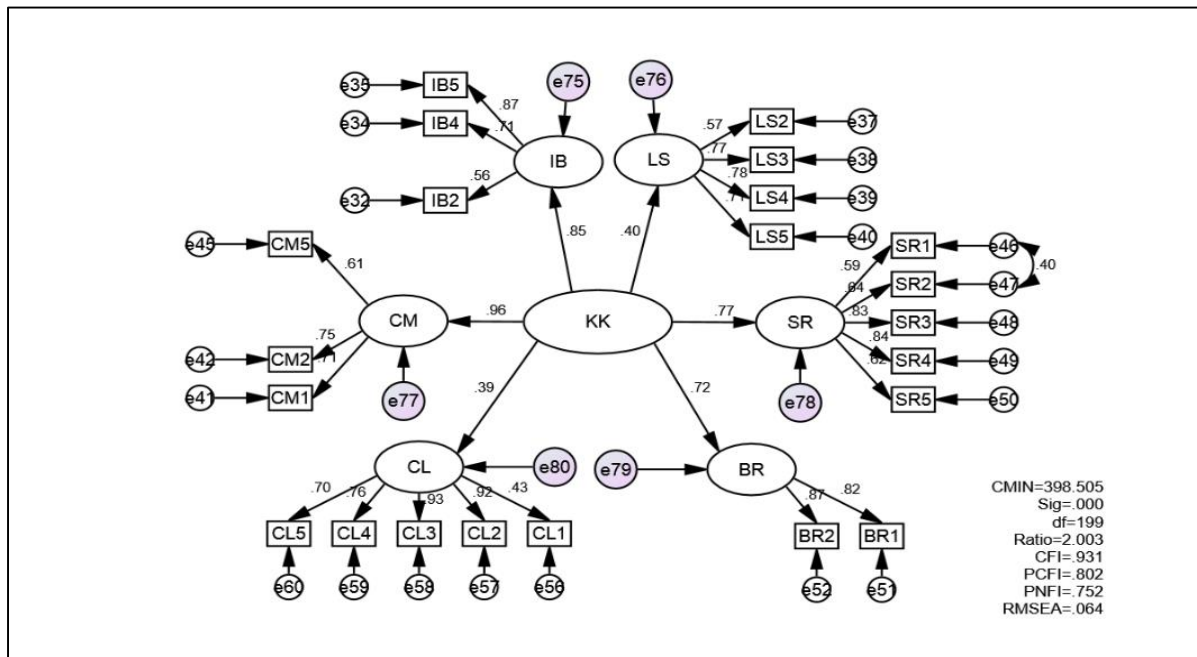

Figure 2. The Model of Virtual Collaborative Community in Education

## Discussion and Conclusion

Overall, this study has successfully developed a model of virtual collaborative community to support the national education agenda. This model has verified the Epstein's Model for Parental Involvement. Unlike Epstein's model, this model is developed based on our national education system and practices. Furthermore, this finding has also verified six functions or constructs of community involvement namely parenting, communicating, learning at home, decision making, smart partnership and volunteering with 26 behaviors. For other functions, improvement needs to be done because the findings show some behaviors are not represented by the proposed indicator. This does not mean that the behaviors are not contributing, but it is at a minimal level. For example, the finding shows that parents are less likely to monitor the homework provided by teachers although at the same time some parents help their children to do their homework. It is also indicating that there are weaknesses in preparing homework logbooks for parental checks and helping parents to set academic achievement targets. In this case, the government especially the Ministry of Education needs to increase the role of parents through the parents' toolkit programs. In the context of communication, an alternative should be taken by school principals in establishing virtual communication between school and community. This is because the indicator items have clearly represented the behavior of creating virtual communication channels such as WhatsApp, Telegram, Facebook, and other virtual communication platforms. While the principals' behaviors in practicing the open-door policy have received community attention, but in addressing the challenges of communication in the Industrial Revolution 4.0, these behaviors need to be taken seriously by the school leaders from now on. Finally, the success of developing this model is expected to contribute and guide the principals in establishing effective engagement between their schools and the community. However, improvements should be made to this model by conducting further studies, including by testing the structural model.

## References

- [1] Airasian, P. W., Gay, L. R., & Mills, G. E. (2011). *Educational research: Competencies for analysis and applications (10th Edition)*. Upper Saddle River, NJ: Pearson Education.
- [2] Aziah Ismail, & Abdullah, A. G. K. (2013). Parents' involvement in Malaysian autonomous schools. *International Journal of Asian Social Science*, 3(3), 657–668.
- [3] Byrne, B. M. (2010). *Structural equation modelling with AMOS: Basic concepts, applications and programming* (2nd ed.). New York: Routledge, Taylor and Francis Group.
- [4] Byrne, B. M. (2013). *Structural equation modelling with LISREL, PRELIS and SIMPLIS: Basic concepts, applications and programming*. Psychology Press.
- [5] Coutts, M. J., Sheridan, S. M., Kwon, K., & Semke, C. (2012). The effect of teacher's invitations to parental involvement on children's externalizing problem behaviors: An examination of a CBC intervention. Nebraska Center for Research on Children, Youth, Families and Schools. CYFS Working Paper 2012-3.
- [6] Epstein, J. L. (1986). Parents' reactions to teacher practices of parent involvement. *The Elementary School Journal*, 86(3), 277. <http://doi.org/10.1086/461449>
- [7] Epstein, J. L., & Sanders, M. G. (2006). Prospect for Change: Preparing Educators for School, Family and Community Partnerships. *Peabody Journal of Education*, 81(2), 81–120.
- [8] Fornell, C & Larcker, D. F. (1981). Evaluating structural equation models with unobservable variables and measurement error. *Journal of marketing research*, 39- 50.
- [9] Gross, J. M. S., Haines, S. ., Hill, C., G.L, F., Blue-Manning, M., & Turnbull, A. P. (2015). 2015. Strong School-community partnerships in inclusive schools are "Part of the fabric of the school....we count to them. *School Community Journal*, 25(2), 9–34.

- [11] Hair, J. F., Black, W. C., Babin, B. J., & Anderson, R. E. (2010). *Multivariate data analysis* (Seventh Ed). Pearson Prentice Hall.
- [12] Hair, J. F., Money, A. H., Samouel, P., & Page, M. (2007). *Research method for business*. John Wiley & Sons. Ltd.
- [13] Jöreskog, K. G., & Sörbom, D. (1986). *LISREL VI. Analysis of linear structural relationships by maximum likelihood, instrumental variables, and least squares methods*. Mooresville, Indiana: Scientific Software.
- [14] Kementerian Pendidikan Malaysia. (2013). *Pelan Pembangunan Pendidikan Malaysia 2013 - 2025 (Pendidikan Prasekolah hingga Lepas Menengah)*. Putrajaya: Kementerian Pendidikan Malaysia.
- [15] Krejcie, R.V and Morgan, D.W. (1970). Determining sampel size for research activities. *Educational and Psychological Measurement*, 30(3), 607-610.
- [16] Lodico, M. G., T., Dean, Spaulding, & Voegtle, K. H. (2010). *Methods in educational research from theory to practice* (Second edi). San Francisco: Jossey - Bass.
- [17] Mattar, D., Pansiri, N. O., Heck, R. H., Shatzer, R. H., Caldarella, P., Hallam, P. R., ... Mokhele, M. L. (2013). Principals' instructional leadership and school performance: implications for policy development. *Journal of Educational Administration*, 48, 130–141. <http://doi.org/10.1177/1094670509353043>
- [18] Meyers, L. S., Gamst, G., & Guarino, A. J. (2013). *Applied multivariate research: Design and interpretation*. (2nd ed.). London: Sage Publication.
- [19] Mohammed Sani, Ibrahim Saedah, S., & Norlidah, A. (2014). *Pengurusan kerja rumah yang efektif*. Kuala Lumpur: Penerbit Universiti Malaya.
- [20] Mohammed Sani, I., Ahmad Zabidi, A. R., Husaina Banu, K., Mohd Sani, I., Ahmad Zabidi, Abdul Razak, Husaina Banu, K., Mohammed Sani, I., ... Ahmad Zabidi, Abdul Razak, Husaina Banu, K. (2013). Smart principals and smart school. 13th *International Educational Technology Conference*, 103(826–836), 826–836. <http://doi.org/10.1016/j.sbspro.2013.10.404>
- [21] Mohammed Sani, I., & Jamalul Lail, A. W. (2012). *Kepimpinan pendidikan*. Bangi: Penerbit UKM.
- [22] Mohd Yusri, I. (2012). *Model Kepimpinanpengajaran pengetua efikasi dan kompetensi pengajaran*. Tesis Doktor Falsafah, Universiti Malaysia Terengganu.
- [23] Paezah, A. H., & Faridah, Y. (2017). Kepentingan penglibatan ibu bapa dalam aktiviti pembelajaran kanak-kanak di prasekolah. In *Perseidangan Antarabangsa Sains Sosial dan Kemanusiaan*.
- [24] Sander, M. . (2001). The role of community in comprehensive school, family, and community partnership programs. *The High School Journal*, 88(3), 1–9.
- [25] Sanders, M. G., & Epstein, J. L. (2005). *School-family-community partnerships and educational change: International Perspectives*. Retrieved from <http://link.springer.com/book/10.1007%2F1-4020-4453-4>.
- [26] Sheldon, S. . (2015). *Moving beyond monitoring: A district leadershipapproach to school, family,and community partnership*. In *Family school partnership in context*. Springer International Publishing.
- [27] Simon, S. (2017). A study of primary school parents ' interaction with teachers ' in Malaysia. *International Journal of Educational and Pedagogical Sciences*, 11(2), 354–361.

- [28] Siti Aliah, I., Muhamad Suhaimai, T., & Jamaluddin, M. A. (2016). Permuafakatan sekolah dengan komuniti dalam pendidikan : Peranan kepimpinan transformasional dan komunikasi pengetua. *In International Confrence on Posstgraduate research 2016* (pp. 382–401).
- [29] Zainuddin, A. (2015). *SEM made simple a gentle approach to learning structural equation modelling*. Bandar Baru Bangi: MPWS Rich Resources.